



**KONKRETE KONCEPTS COMPANY**



Customised **Solutions**  
For **Specified Needs**



## BENEFITS OF PRECAST CONCRETE

**Strength** - The Strength of precast concrete gradually increase over time . Other materials can deteriorate, experience creep and stress relaxation, loss strength and/ or deflect over time. The load carrying capacity of precast concrete is delivered form its own structural qualities and dose not rely on the strength or the strength or quality of the surrounding backfill materials.

**Durability**- Studies have shown that precast concrete products can provide a service life in excess of 100 years. For severe service conditions, additional design options are available which can extend the life of the precast concrete product. This is extremely important when calculating life cycle cost for a project.

**Mass**- Precast concrete products can act as effective barriers to vehicular traffic due to their size and weight. In the current world climate, precast concrete products such as planters, bollards and highway barriers increasingly are being used to provide protection for a wide variety of venues.

**Chemical Resistance**- Precast is resistant to most substances. However no material is completely immune tor attack form aggressive chemical agents. Thus it is wise to choose the material with the longest expected service life. Precast concrete products can be designed to withstand anticipated corrosive agents.

**Quality Control**- Because precast concrete products typically are produced in a controlled environment they exhibit high quality and uniformity. variables affecting quality typically found on a jobsite-temperature, humidity material quality craftsmanship-are nearly eliminated in a plant environment.

**UV Sensitivity**- Unlike some other some other materials, precast concrete does not degrade from exposure to sunlight. This is extremely beneficial for above-ground applications.

**Environmentally Friendly** - After water, concrete is the most frequently used material on earth. it is nontoxic, environmentally safe and composed of natural materials. Buried throughout the world, precast concrete products help convey water contributing to poor water quality.

**Weather Resistance**- Precast concrete is well-suited for exposures to all types of weather conditions.

**Reduced Weather Dependency** - Precast increases efficiency because weather will not delay production. In additional weather conditions at the jobsite do not significantly affect the schedule. This is because it requires less time to install precast compared with other construction methods, such as cast-in-place concrete. Precast concrete can be easily installed on demand and immediately backfilled- there is no need to wait for it to cure.

**Water Tightness** - Standard watertight sealants are specially formulated to adhere to precast concrete, Making watertight multiple-seam precast concrete structures possible.

**Ease of Installation**- Since precast products are designed and manufactured for simple connection, many components can be installed in a short time.

**Modularity** - Because of the modular nature of many precast concrete products, structures of systems of nearly any size can be installed in a short time.

**Efficiency** - Precast concrete products arrive at the jobsite ready to install. There is no need to order raw materials such as reinforcing steel and concrete, and there is no need to spend time setting up forms, placing concrete or waiting for the concrete to cure.

**Aesthetics** - Precast concrete products are both functional and decorative. They can be shaped and molded into an endless array of size and configurations. Precast concrete can also be produced in virtually any color and a wide variety of finishes (acid-etched, sand blasted, smooth-as-cast, exposed-aggregate) to achieve the desired appearance for building and site application.

**Low Maintenance**- Precast concrete requires or on maintenance, which makes it an ideal choice for nearly any design solution.

**Fire Resistance**- Precast concrete is noncombustible, Also, concrete does not its structural capacity nearly as quickly as steel. Other materials besides concrete and steel are flammable and / or do not perform well in elevated temperature.





# FURNITURE GALLERY





CHAIR BENCH WITH BACK REST  
INDIAN RAILWAY



**CHAIR BENCH WITH TERRAZZO FINISH**

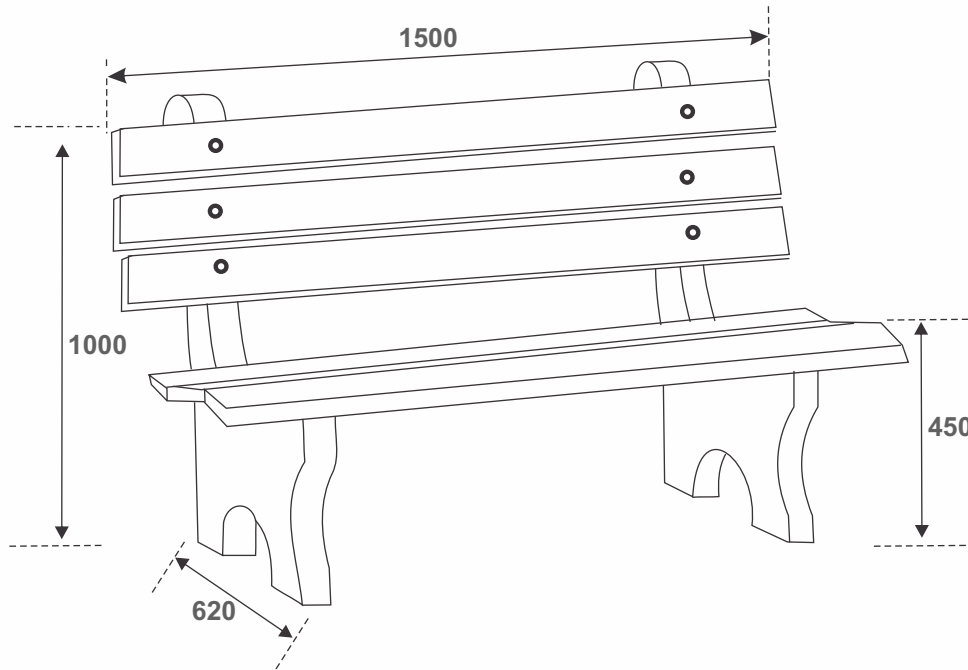

- Each bench consists of 2 Nos. L-shape base support in grey cement color (thickness; 100mm, Back height ; 1000mm, front height 450 mm, Base width ;620mm) and 5 Nos. reinforced

concrete planks in red Terrazzo Finish of size 1500mm x 100mm x 50mm, and 1 No. of reinforced concrete plank of size 1500mm x 200mm x 50mm

- Overall Dimension : Seating length of the Bench: 1500 mm, Seating height of the Bench 450 mm, Total height of the Bench: 1000mm

**COLOR AVAILABILITY :**

RED	YELLOW	GREY	GREEN
			

Konkrete Concepts Precast Concrete Products are manufactured by using color concrete, fibre concrete and polymer concrete grade of M-30 and above. We use latest vibro-compaction techniques to manufacture our products. In our constant endeavour to improve the products, the specifications may change without notice.

(All Dimension are in mm.)

e-mail : [konkretkoncepts@gmail.com](mailto:konkretkoncepts@gmail.com)



**CHAIR BENCH WITH HAND REST**

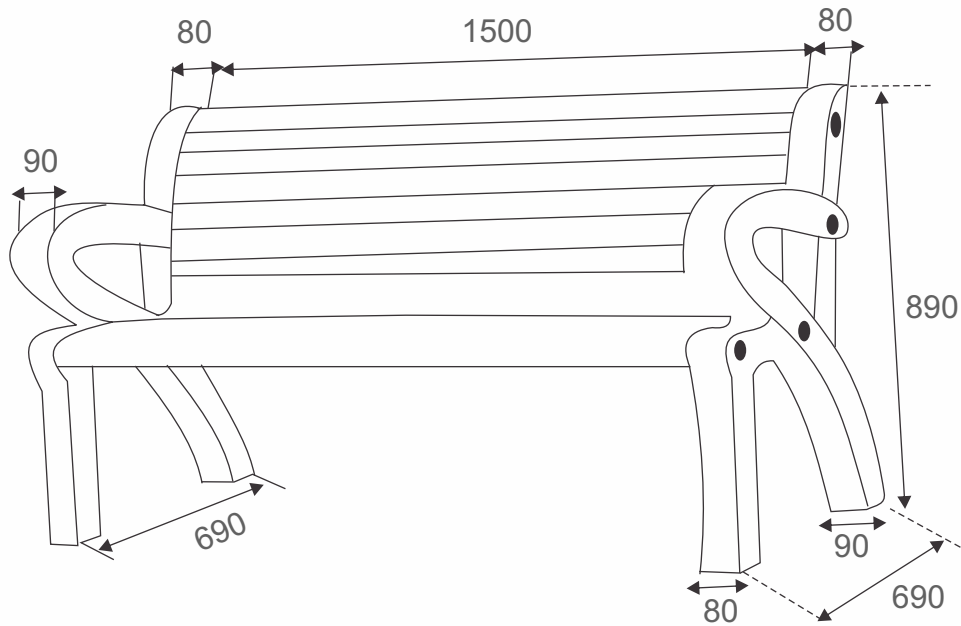

- Each bench consists of 2 Nos L-shape base support in grey cement color (thickness : 80 mm, Back height : 890 mm, Front height 450 mm and Base width 690mm) and 1 Nos. reinforced

concrete planks in red color of size 1500mm x 400mm x 50mm, and 1 no. of reinforced concrete plank in red colour of size 1500mm x 425mm x 50mm.

- Overall Dimension : Seating length of the Bench: 1500 mm, Seating height of the Bench 450 mm, Total height of the Bench: 890mm

**COLOR AVAILABILITY :**

RED	YELLOW	GREY	GREEN
			

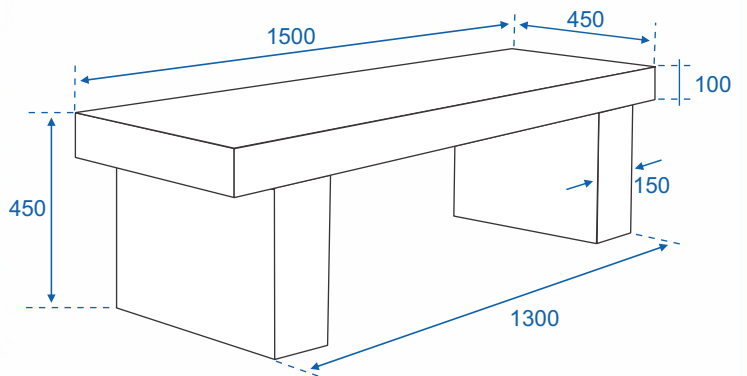

### RECTANGULAR BENCH

- Overall Dimensions : Platform size - 1500mm length 450 mm width, 100mm thickness and 450 mm height with two legs of 150 mm thickness.
- Sitting Platform is in Red colour while the legs are in grey colour
- Manufactured by using M-30 grade of Concrete
- Suitably reinforced to promote long use and to prevent damage during handling, transportation & erection
- Treated with special anti-corrosive, water proof coating so as to make the surface glossy and water proof

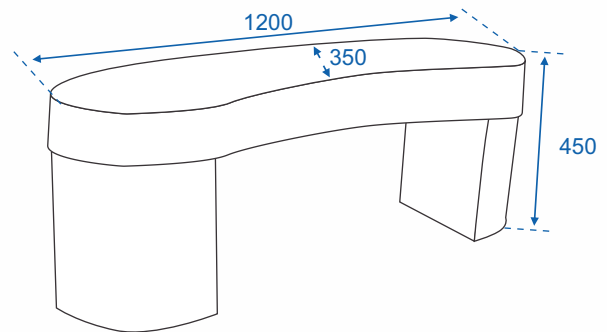

### CURVED BENCH

- Overall Dimensions : Platform size - 1200mm length 350 mm width, 450mm height
- Sitting Platform is in Red colour while the legs are in grey colour
- Manufactured by using M-30 grade of Concrete
- Suitably reinforced to promote long use and to prevent damage during handling, transportation & erection
- Treated with special anti-corrosive, water proof coating so as to make the surface glossy and water proof

**COLOR AVAILABILITY :**

RED	YELLOW	GREY	GREEN
			

Konkrete Concepts Precast Concrete Products are manufactured by using color concrete, fibre concrete and polymer concrete grade of M-30 and above. We use latest vibro-compaction techniques to manufacture our products. In our constant endeavour to improve the products, the specifications may change without notice.

(All Dimension are in mm.)

e-mail : [konkretkoncepts@gmail.com](mailto:konkretkoncepts@gmail.com)

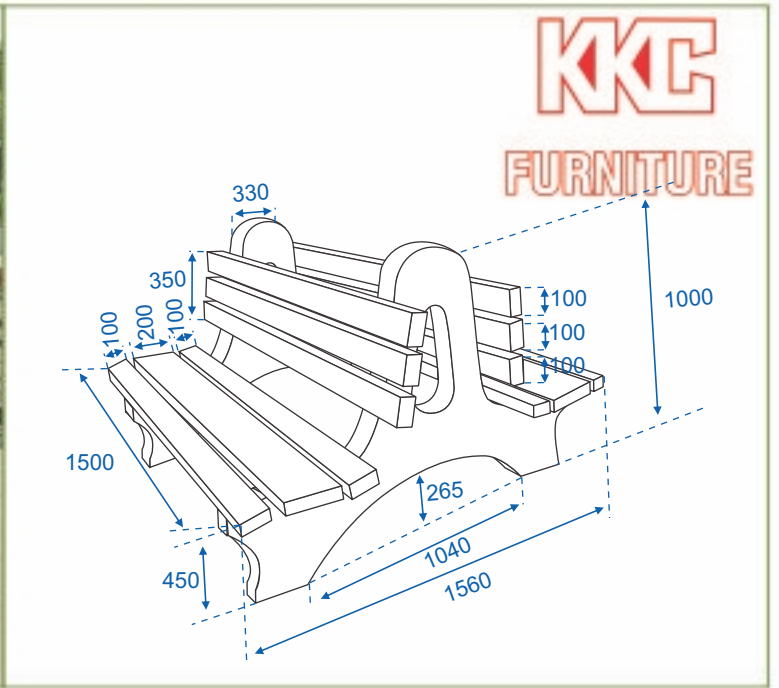

## DOUBLE SIDE CHAIR BENCH WITH BACK REST

- Each bench consists of 2 Nos. base support in grey cement colour (Thickness; 100mm, Back height ; 1000mm, Front height 450 mm, Base width ; 1435 mm) and 10 Nos. reinforced concrete planks in red colour of size 1500mm x 100mm x 50mm, and 2 No. of reinforced concrete plank of size 1500mm x 200mm x 50mm (Planks can be in red color or Terrezzo finish
- Overall Dimension : Seating length of the Bench: 1500 mm, on one side & 1500mm on the opposite side Seating height of the Bench 450mm Total height of the Bench 1000mm

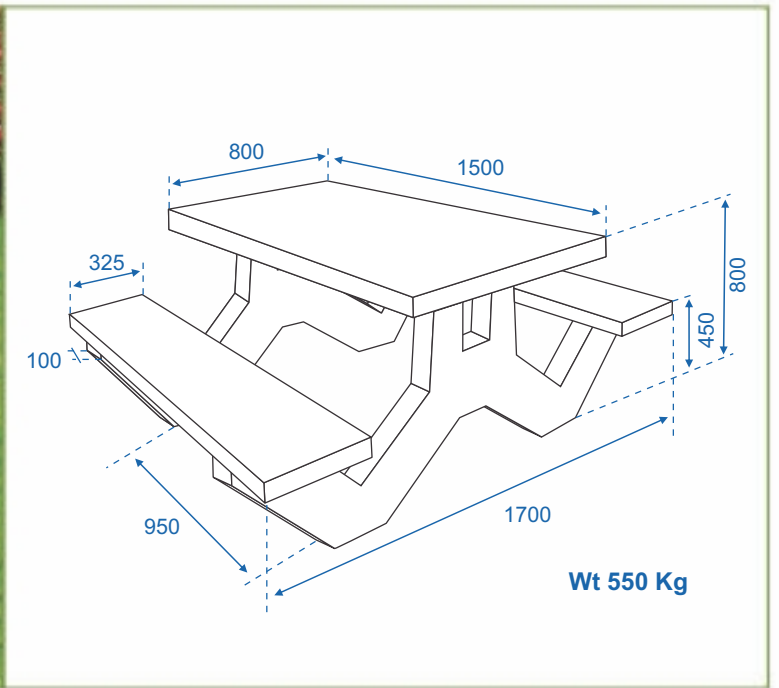

## RECTANGULAR TABLE WITH TWO BENCH

- Consists of 2 Nos. Base support in grey cement concrete, Table top of size 1500mm length x 800mm width x 50mm thickness in red color of terrazzo finish, and 2 Nos. benches of size 1500mm length x 325mm width x 50mm thickness in red color or terrazzo finish
- Overall Dimension : Height of table : 800 mm Height of bench : 450mm

**COLOR AVAILABILITY :**

RED	YELLOW	GREY	GREEN
			

Konkrete Concepts Precast Concrete Products are manufactured by using color concrete, fibre concrete and polymer concrete grade of M-30 and above. We use latest vibro-compaction techniques to manufacture our products. In our constant endeavour to improve the products, the specifications may change without notice.

(All Dimension are in mm.)

e-mail : [konkretkoncepts@gmail.com](mailto:konkretkoncepts@gmail.com)





**KKC**  
**FLOORING**

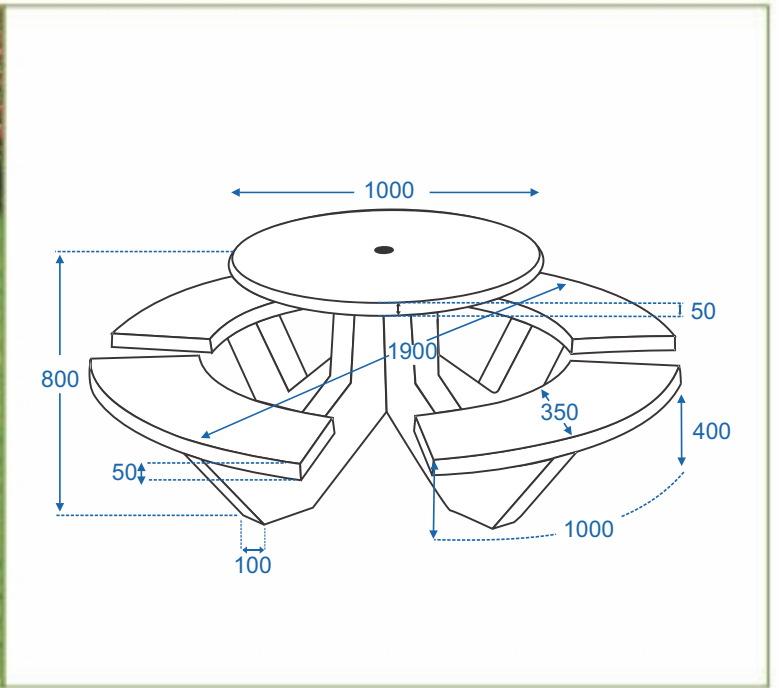

### CIRCULAR TABLE WITH FOUR BENCH

- Consists of 2 Nos. Base support in grey cement concrete, Table of size 1000mm dia. X 50mm thickness in terrazzo or red color finish, and 4 nos. benches of size

1000mm length x 350mm width x 50mm thickness in terrazzo or red color finish (curved)

- Overall Dimension : Height of table : 800mm; Height of benches : 450mm

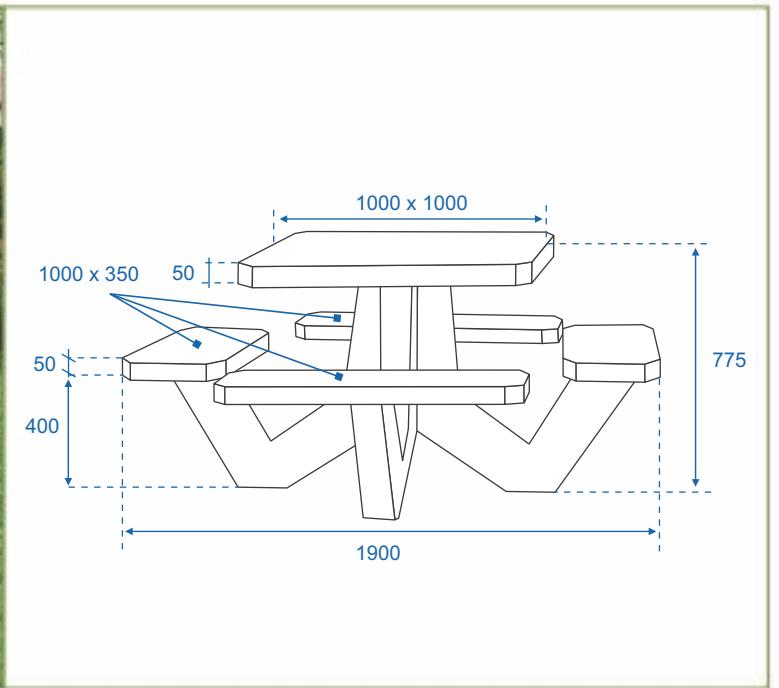

### SQUARE TABLE WITH FOUR BENCHES

- Consists of 2 Nos. Base support in grey cement 1 Nos. Table top of size 1000mm x 1000mm width x 50mm thickness in terrazzo or red color finish, and 4 Nos. Benches of

size 1000mm length x 350mm width x 50mm thickness in terrazzo or red color finish

- Overall Dimension : Height of table : 800mm Height of benches : 450mm

**COLOR AVAILABILITY :**

RED	YELLOW	GREY	GREEN
			



# FLOORING

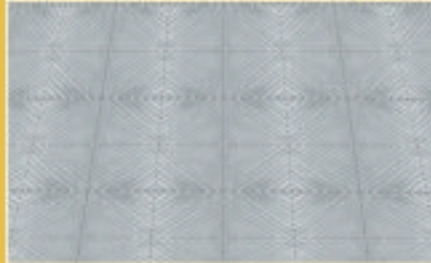
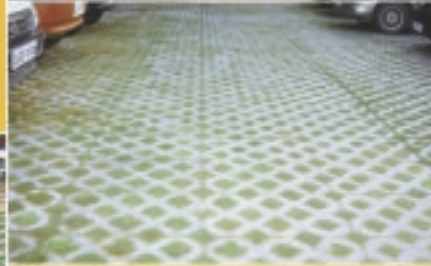



**RAILWAY PLATFORM COPINGS**  
New Delhi Railway Station

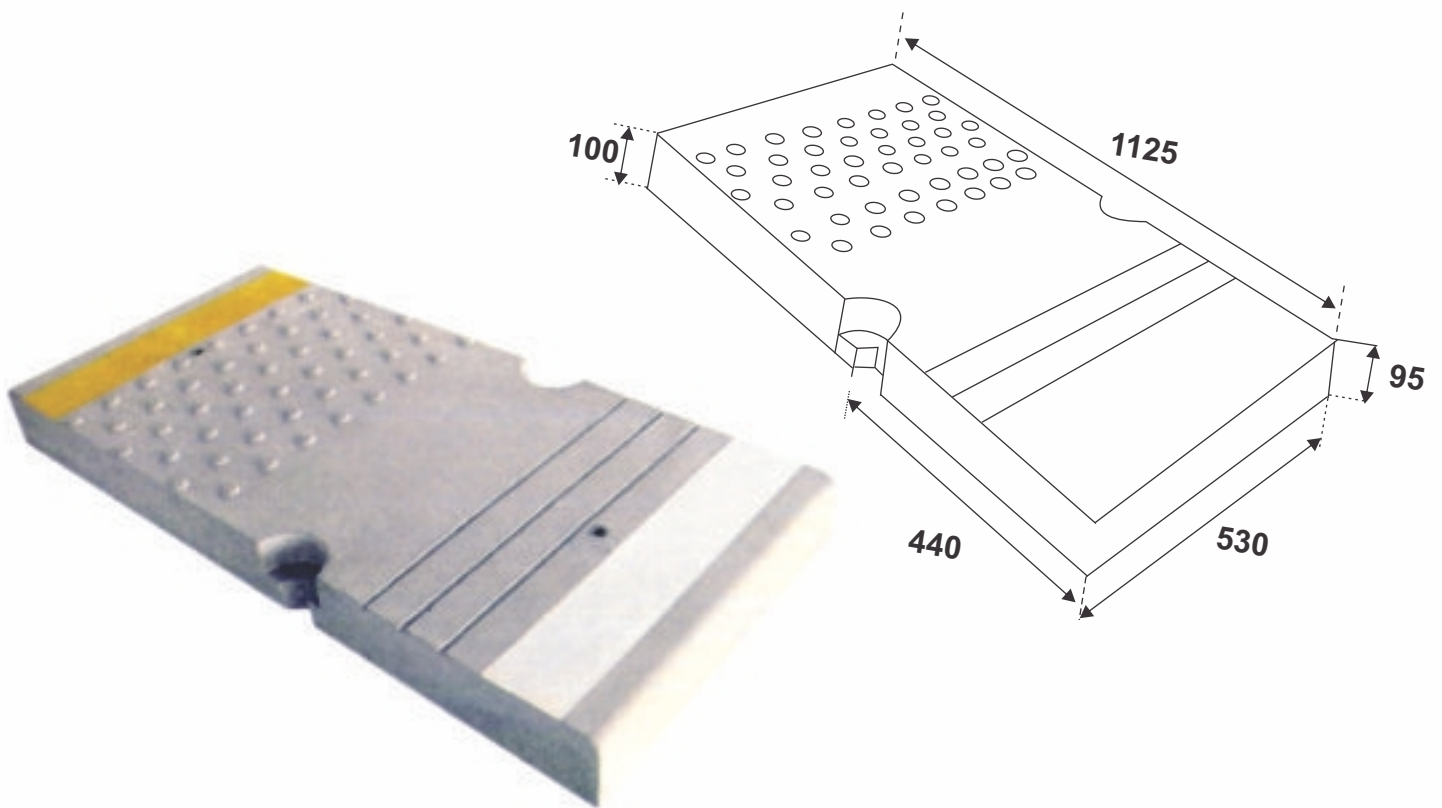

**COLOR AVAILABILITY :** RED    YELLOW    GREY    GREEN

Konkrete Concepts Precast Concrete Products are manufactured by using color concrete, fibre concrete and polymer concrete grade of M-30 and above. We use latest vibro-compaction techniques to manufacture our products. In our constant endeavour to improve the products, the specifications may change without notice.

(All Dimension are in mm.)

e-mail : [konkretkoncepts@gmail.com](mailto:konkretkoncepts@gmail.com)



**GRASS GRID**

Gautam Budh University, Greater Noida

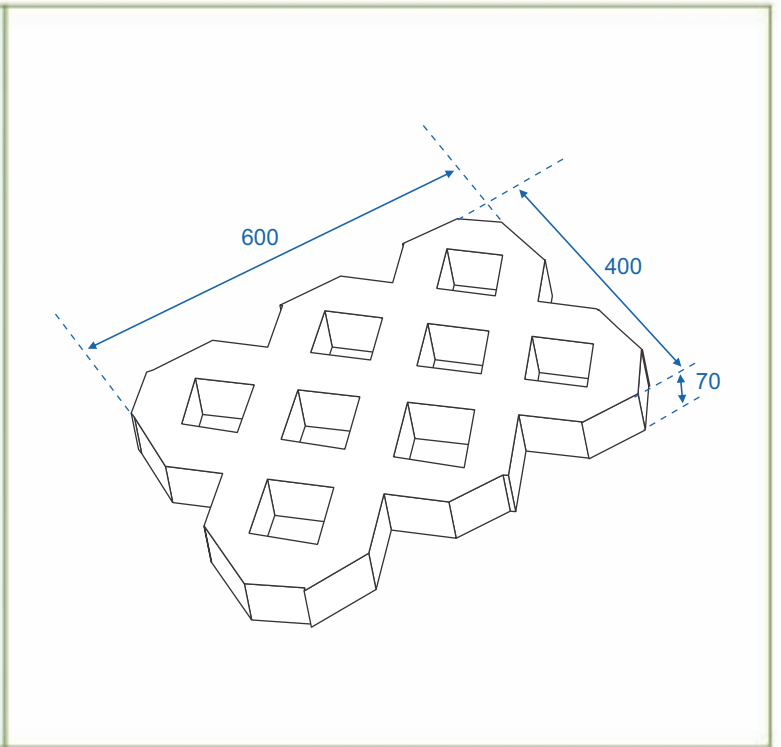

**COLOR AVAILABILITY :** RED    YELLOW    GREY    GREEN

Konkrete Concepts Precast Concrete Products are manufactured by using color concrete, fibre concrete and polymer concrete grade of M-30 and above. We use latest vibro-compaction techniques to manufacture our products. In our constant endeavour to improve the products, the specifications may change without notice.

(All Dimension are in mm.)

e-mail : [konkretkoncepts@gmail.com](mailto:konkretkoncepts@gmail.com)



**GRASS PAVER**

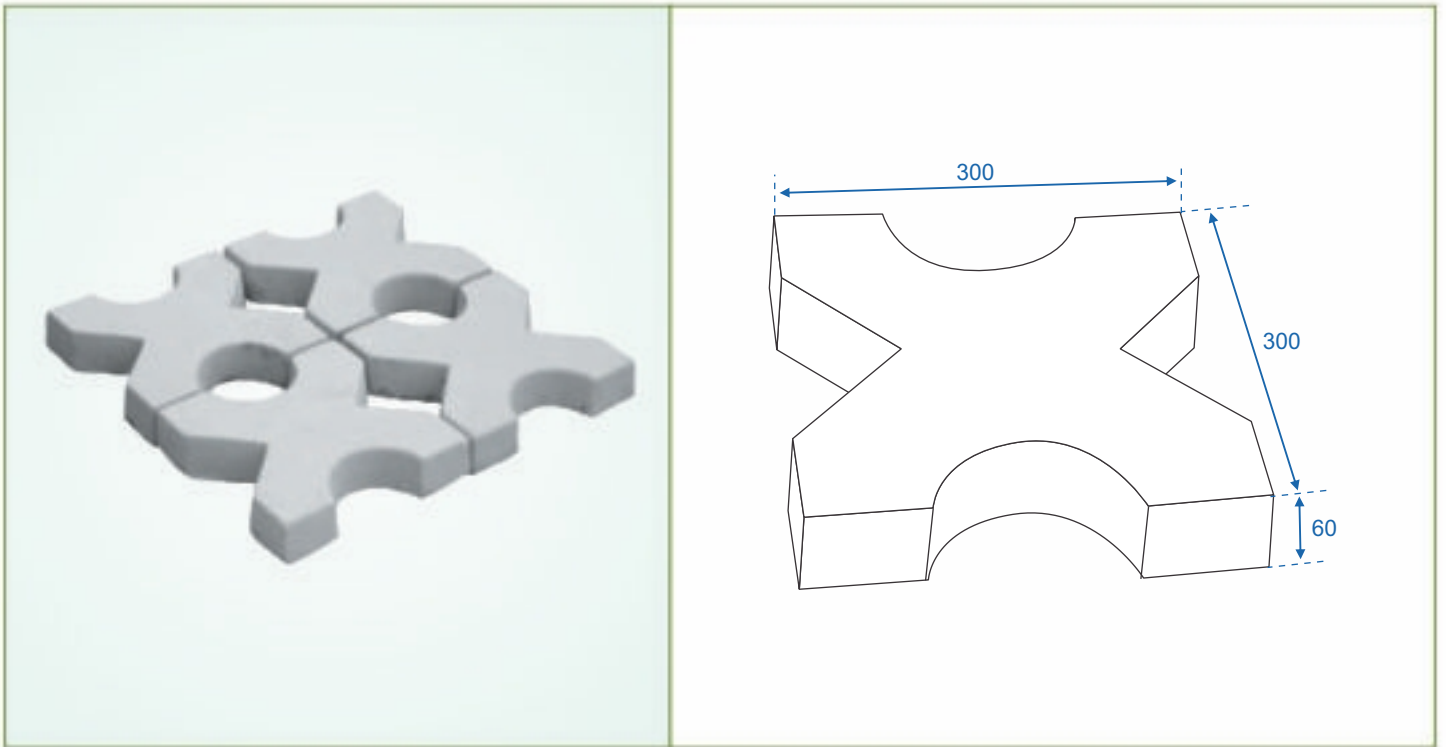

**COLOR AVAILABILITY :**    RED    YELLOW    GREY    GREEN

Konkrete Concepts Precast Concrete Products are manufactured by using color concrete, fibre concrete and polymer concrete grade of M-30 and above. We use latest vibro-compaction techniques to manufacture our products. In our constant endeavour to improve the products, the specifications may change without notice.

(All Dimension are in mm.)

e-mail : [konkretkoncepts@gmail.com](mailto:konkretkoncepts@gmail.com)

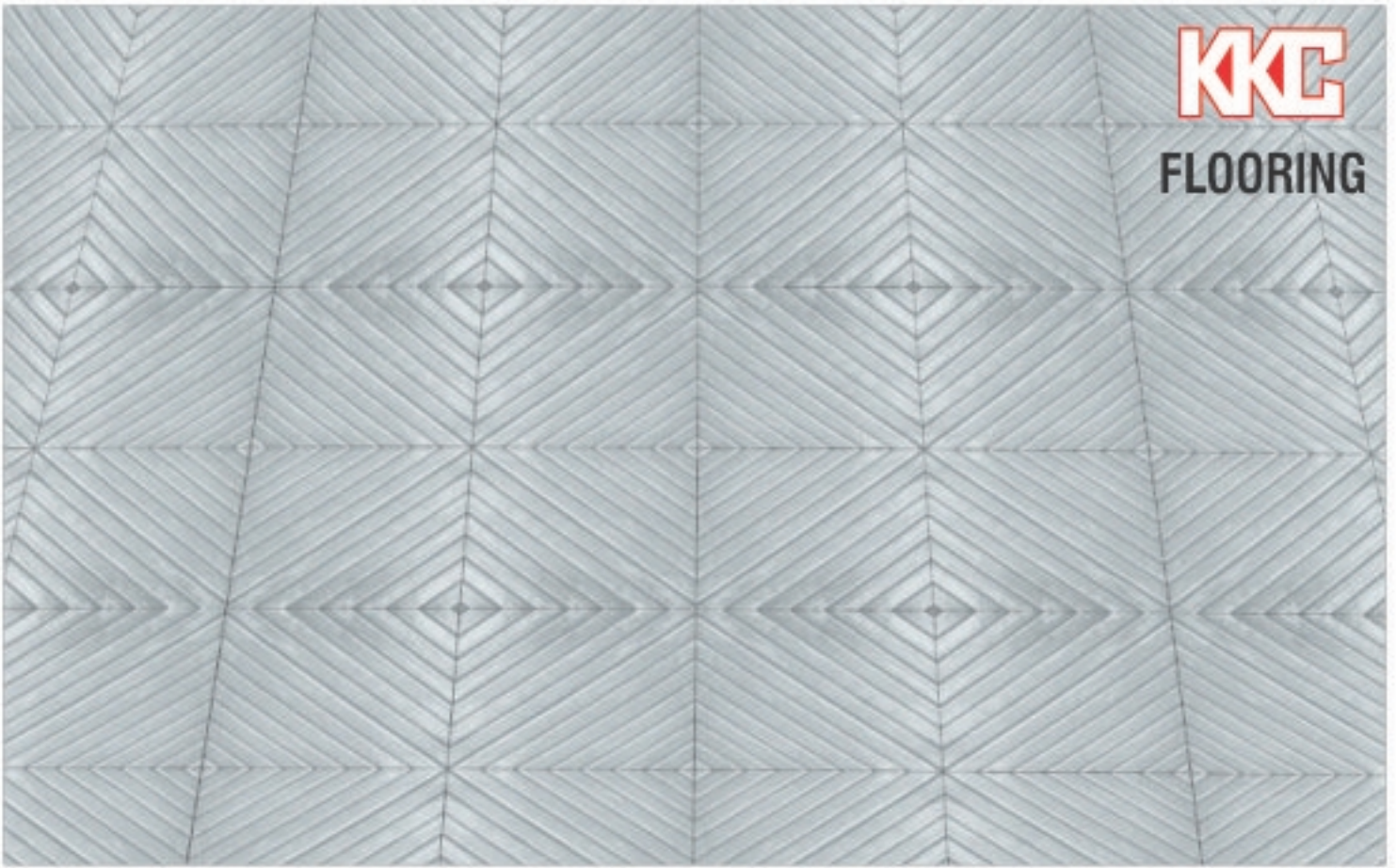

**FLOOR TILE**

**Designer Tile**

Size : 400x400x40/50

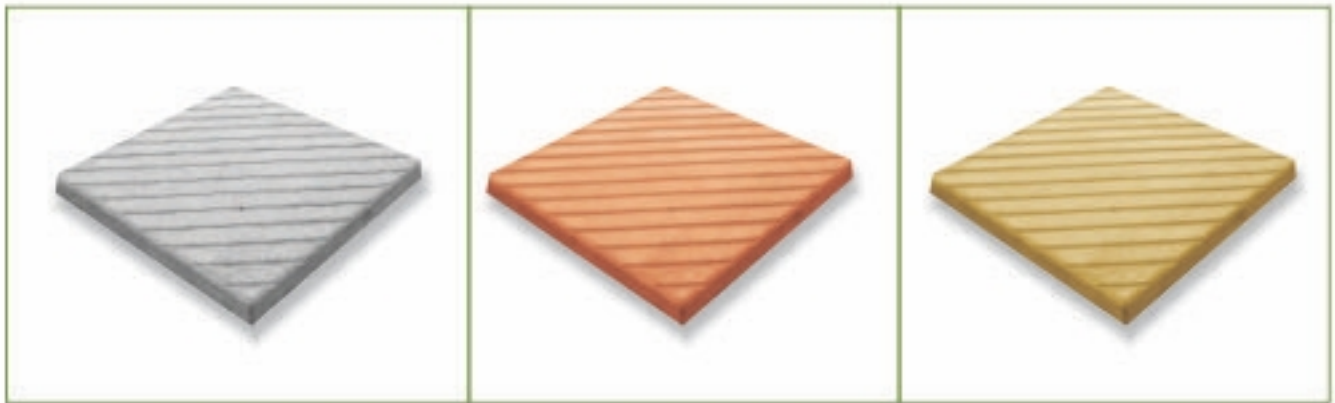



---

Note : Above Tiles can be made in different color finish as per customer requirement and also can be reinforced as per customers specifications.

---

**COLOR AVAILABILITY :**    RED    YELLOW    GREY    GREEN

Konkrete Concepts Precast Concrete Products are manufactured by using color concrete, fibre concrete and polymer concrete grade of M-30 and above. We use latest vibro-compaction techniques to manufacture our products. In our constant endeavour to improve the products, the specifications may change without notice.

(All Dimension are in mm.)

e-mail : [konkretkoncepts@gmail.com](mailto:konkretkoncepts@gmail.com)

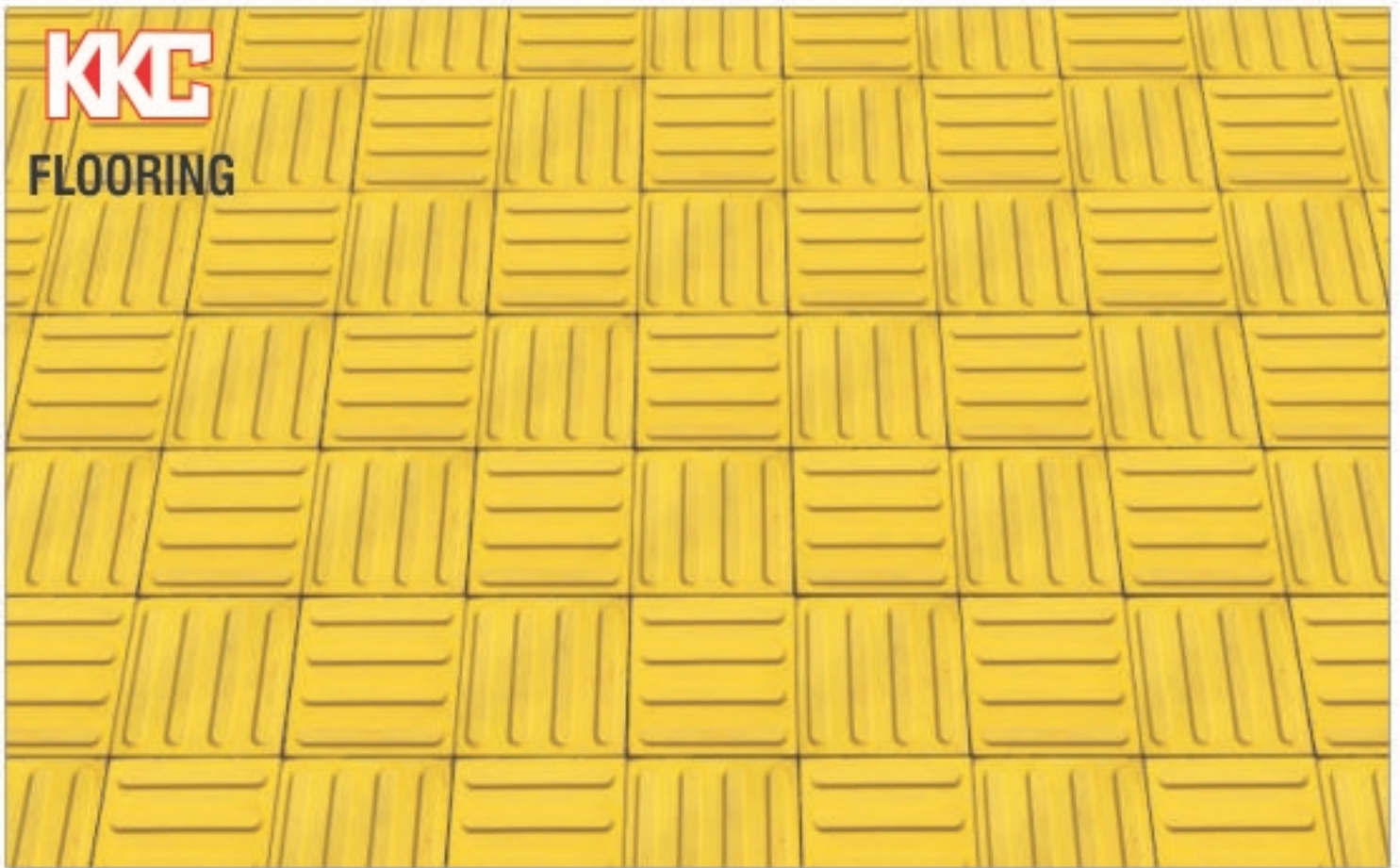

**FLOOR TILE**

**Tactile Type A**

Size : 300x300x60 mm



Note : Above Tiles can be made in different color finish as per customer requirement and also can be reinforced as per customers specifications.

**COLOR AVAILABILITY :**    RED    YELLOW    GREY    GREEN

Konkrete Concepts Precast Concrete Products are manufactured by using color concrete, fibre concrete and polymer concrete grade of M-30 and above. We use latest vibro-compaction techniques to manufacture our products. In our constant endeavour to improve the products, the specifications may change without notice.

(All Dimension are in mm.)

e-mail : [konkretkoncepts@gmail.com](mailto:konkretkoncepts@gmail.com)



**BRICK SLABS**

Size : 300x150x60/80



---

Note : Above Tiles can be made in different color finish as per customer requirement and also can be reinforced as per customers specifications.

---

**COLOR AVAILABILITY :**    RED    YELLOW    GREY    GREEN



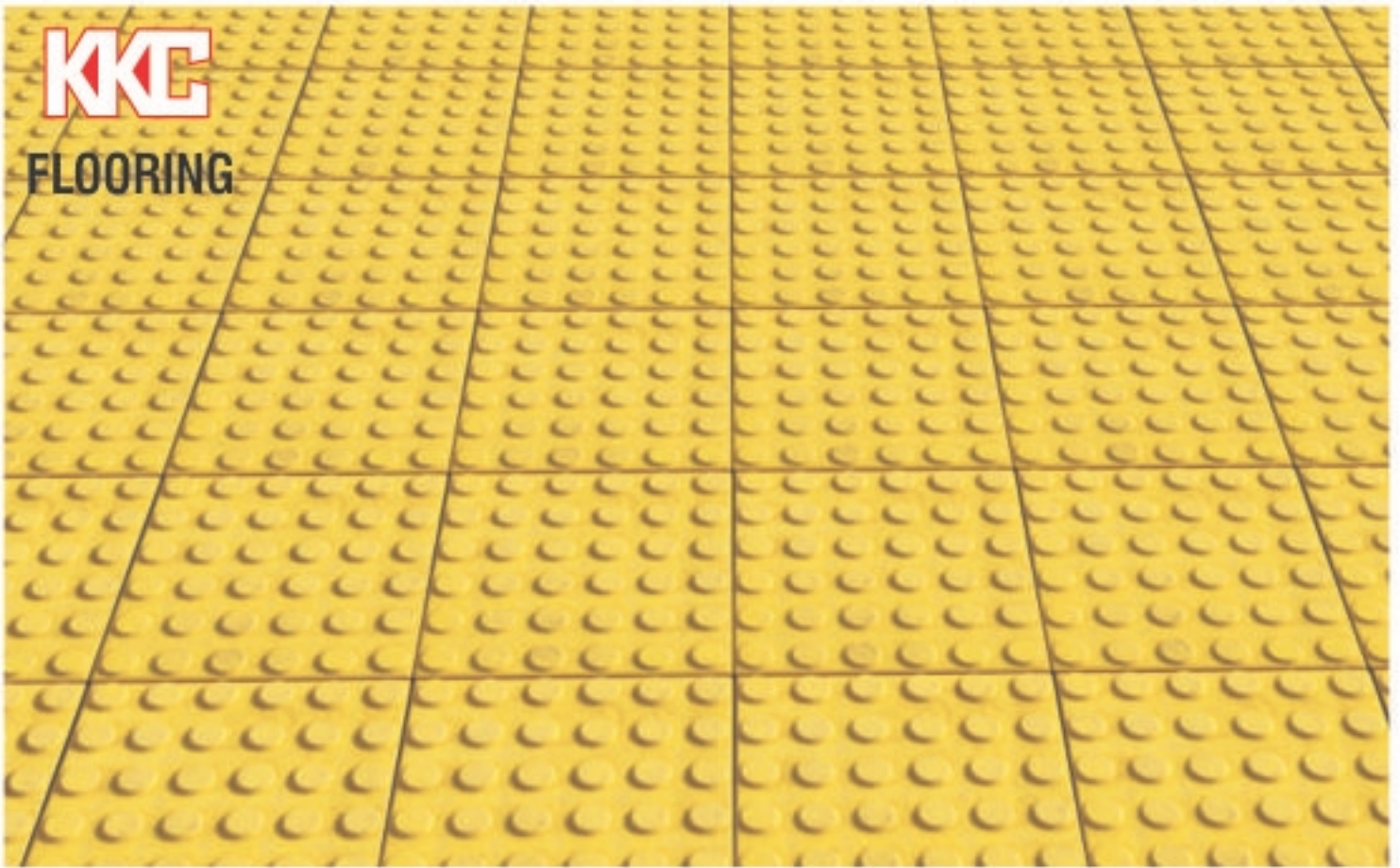

**FLOOR TILE**

**Tactile Type B**

Size : 300x300x60

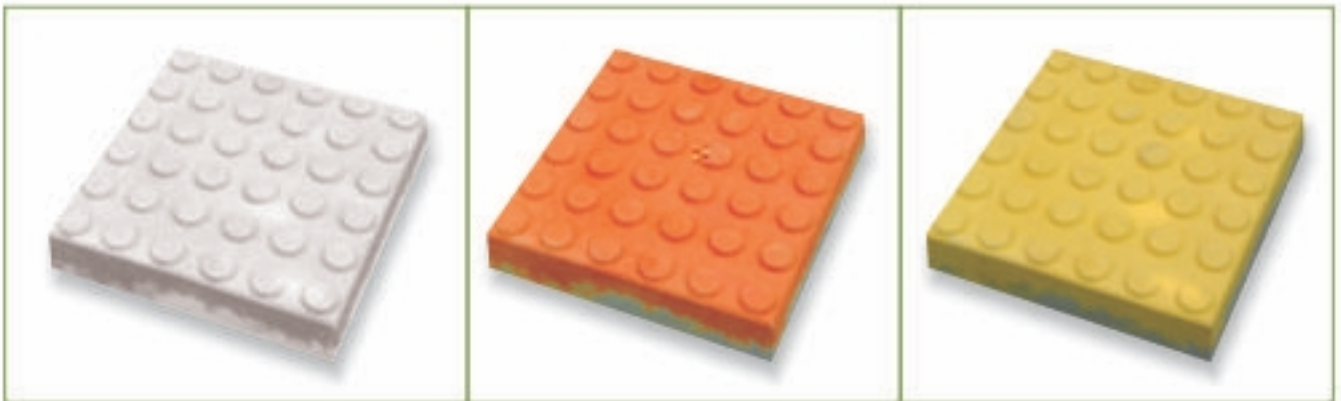

Note : Above Tiles can be made in different color finish as per customer requirement and also can be reinforced as per customers specifications.

**COLOR AVAILABILITY :** RED    YELLOW    GREY    GREEN



# UTILITY GALLERY

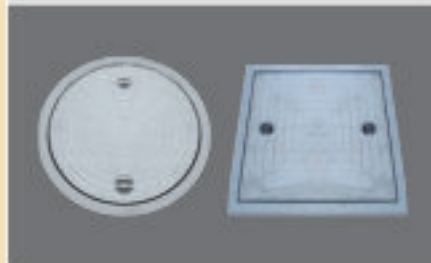
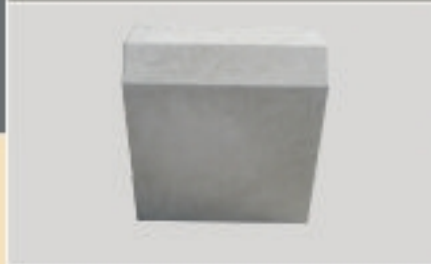



**SIX OR EIGHT FEET BOUNDARY WALL**

**Specification**

**1800 mm (approx. 6ft) High Boundary Wall - 40 mm thickness**  
 Consists of RCC Precast Concrete Post of size 150mm X 150mm X 2435 mm Height having two grooves of size 50 X 30mm, so as to receive 6 Nos. Precast Concrete RCC Panels of size 1500mm x 300mm x 40mm thickness The post is reinforced with 4 Nos. 8 mm dia Tor Bars with 4mm dia stir-ups @ 150mm c/c; Panels are reinforced with 3 Nos. longitudinal bars of 8mm. dia Tor Steel & 6 mm plain M.S. Stir up @ 150 centre to centre. Manufactured by using M-30 grade of concrete

**2400 mm (approx. 8ft) High Boundary Wall - 40 mm thickness**  
 Consists of RCC Precast Concrete Post of size 150mm x 150mm x 3000 mm Height, having two grooves of size 50 x 30mm, so as to receive 8 Nos. Precast Concrete RCC Panels of size 1500mm x 300mm x 40 mm thickness The post is reinforced with 4 Nos. 8 mm dia Tor Bars with 4mm dia stir-ups @ 150mm c/c; Panels are reinforced with 3 Nos. longitudinal bars of 8mm. dia Tor Steel & 6 mm plain M.S. Stir up @ 150 center to center. Manufactured by using M-30 grade of concrete

**Note:** The post may be fixed to the ground by digging a hole of 500 x 500 x 600 mm and filled with 1 : 3 : 6 concrete after the post has been aligned in these holes. The post will be erected @ 1.615m. center to center

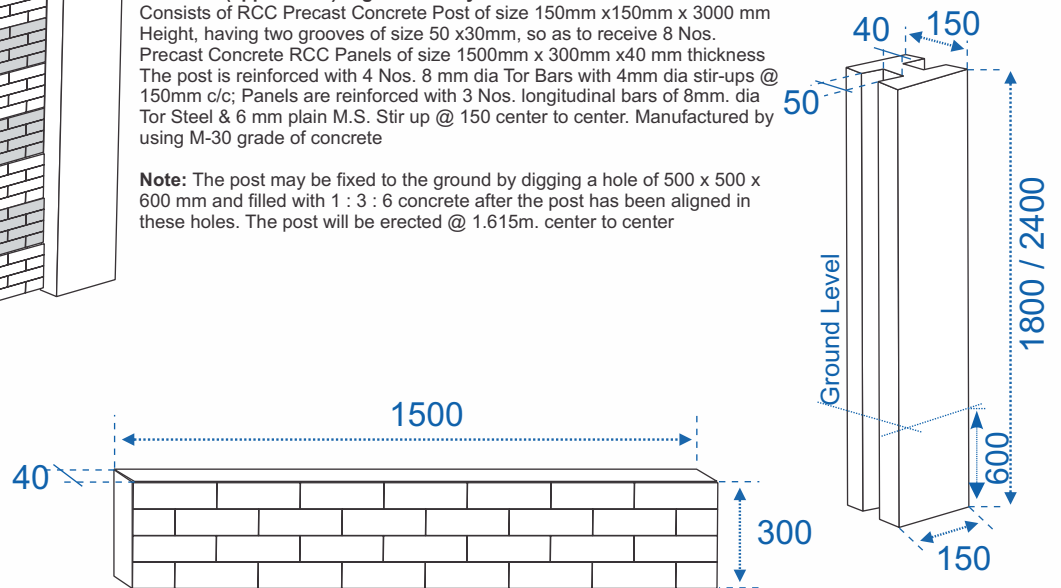
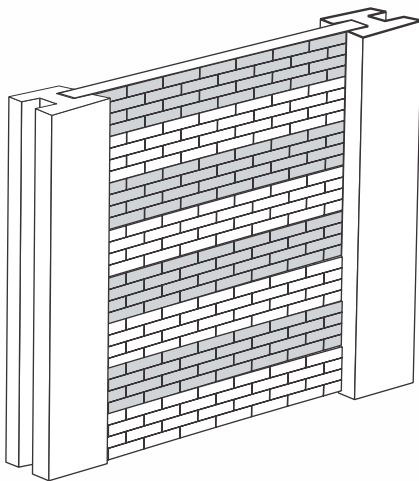



**KKC**  
**UTILITY**

**KERB STONE** MCD Civic center, Delhi

Unitech, Greater Noida

<p>KS - 01</p>	<p>KS - 01a</p>	<p>KS - 02</p>	<p>KS - 03</p>
<p>KS - 04</p>	<p>KS - 05</p>	<p>KS - 05a</p>	<p>KS - 06</p>
<p>KS - 07</p>	<p>KS - 08</p>	<p>KS - 08a</p>	<p>KS - 09</p>
<p>KS - 09a</p>	<p>KS - 10</p>	<p>KS - 11</p>	<p>KS - 12</p>
<p>KS - 13</p>	<p>KS - 14</p>	<p>KS - 17</p>	<p>KS - 18</p>
<p>KS - 19</p>	<p>KS - 19a</p>	<p>KS - 20</p>	

Konkrete Concepts Precast Concrete Products are manufactured by using color concrete, fibre concrete and polymer concrete grade of M-30 and above. We use latest vibro-compaction techniques to manufacture our products. In our constant endeavour to improve the products, the specifications may change without notice.

(All Dimension are in mm.)

e-mail : [konkretkoncepts@gmail.com](mailto:konkretkoncepts@gmail.com)



UTILITY



SLIT DRAIN SYSTEM

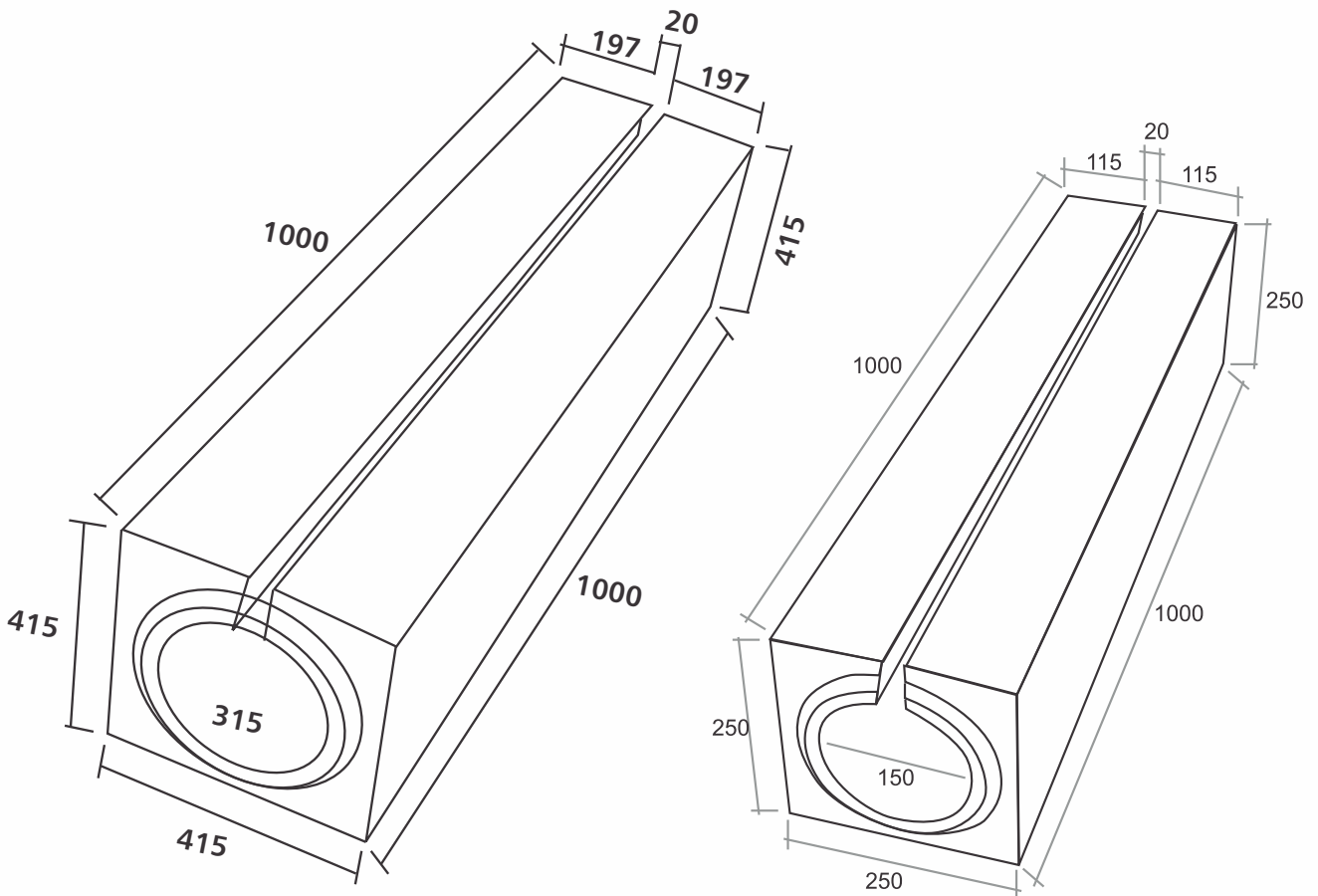

Konkrete Concepts Precast Concrete Products are manufactured by using color concrete, fibre concrete and polymer concrete grade of M-30 and above. We use latest vibro-compaction techniques to manufacture our products. In our constant endeavour to improve the products, the specifications may change without notice.

(All Dimension are in mm.)

e-mail : [konkretkoncepts@gmail.com](mailto:konkretkoncepts@gmail.com)

# ROAD INDICATOR



# UTILITY

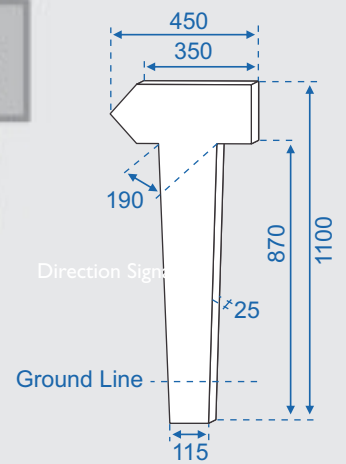
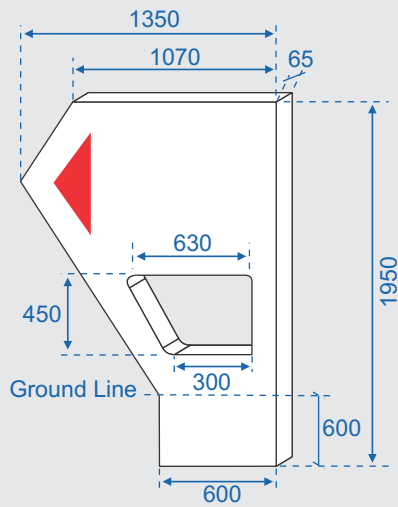

## LONG KERB STONE/KERB STONE/WHEEL STOPPER/ROAD DIVIDER

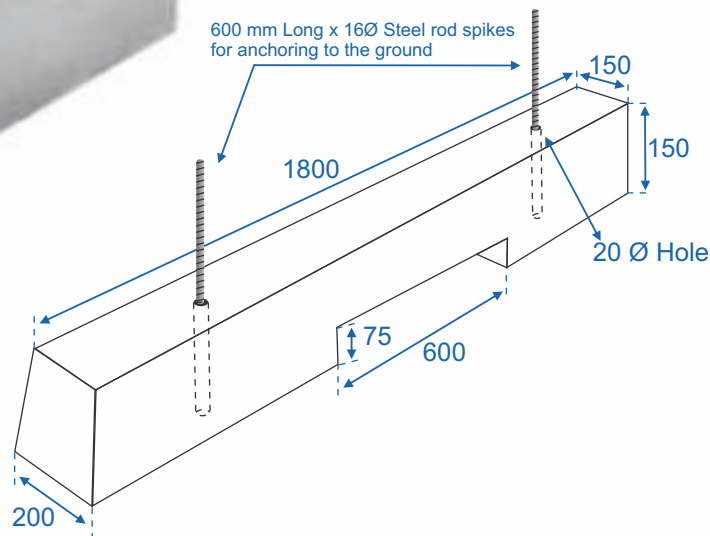
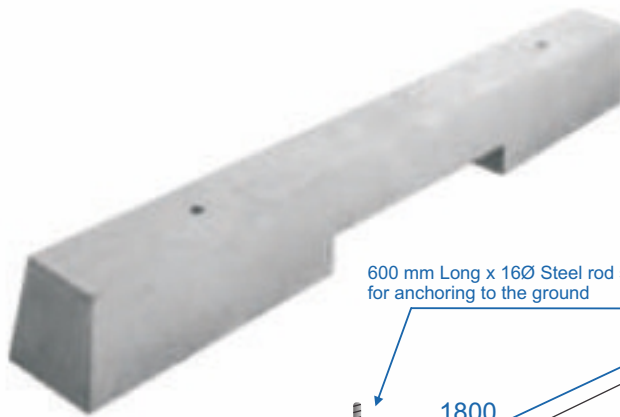

### Advantages of using above kerb stone

1. Faster runoff of water from road to surrounding areas.
2. No water clogging on the roads & hence longer life of the road.
3. Rain water harvesting by the water is possible.
4. Can be used as a sitting area along the footpath.
5. No separate drainage pipe required.



Konkrete Concepts Precast Concrete Products are manufactured by using color concrete, fibre concrete and polymer concrete grade of M-30 and above. We use latest vibro-compaction techniques to manufacture our products. In our constant endeavour to improve the products, the specifications may change without notice.

(All Dimension are in mm.)

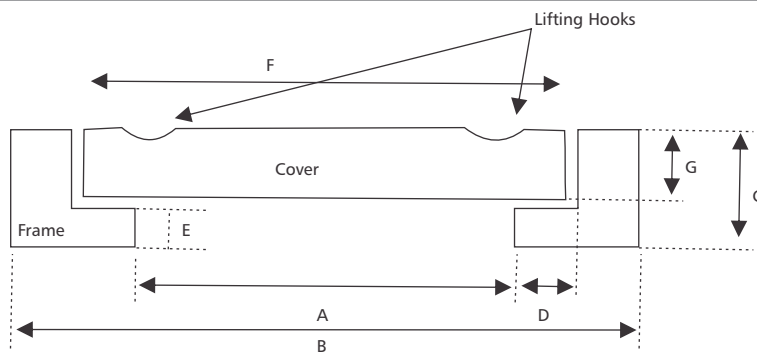
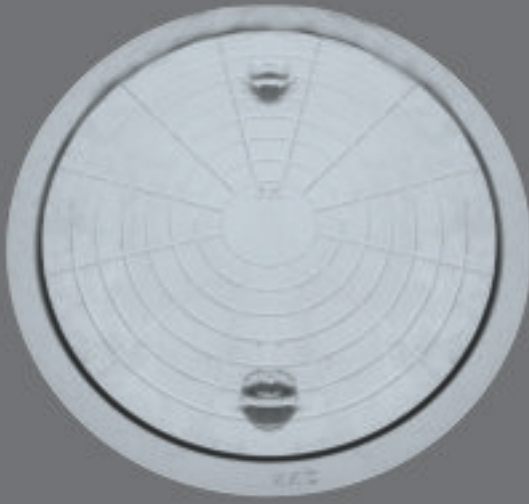
e-mail : [konkretkoncepts@gmail.com](mailto:konkretkoncepts@gmail.com)

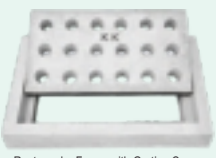
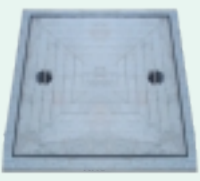

## MANHOLE COVERS, FRAMES AND GRATINGS

Product Picture	Product Code	Product Description	Shape	Frame Details				Cover Details		
				A	B	C	D	E	F	G
	KKC MHCF - 01	Extra Heavy Duty - 35	Circular	560	875	175	75	75	720	100
	KKC MHCF - 01	Heavy Duty - 20	Circular	560	875	155	75	75	720	80
	KKC MHCF - 02	Heavy Duty - 20	Square	600x600	840x840	130	50	50	710x710	80
	KKC MHCF - 03	Heavy Duty - 20	Rectangular	600x450	910x760	155	75	75	760x610	80
	KKC MHCF - 04	Medium Duty - 10	Circular	560	770	110	50	50	670	60
	KKC MHCF - 05	Medium Duty - 10	Square	600x600	810x810	100	50	50	710x710	50
	KKC MHCF - 06	Medium Duty - 10	Square	450x450	660x660	100	50	50	560x560	50
	KKC MHCF - 07	Medium Duty - 10	Rectangular	600x450	810x660	100	50	50	710x560	50
	KKC MHCF - 08	Light Duty- 2.5	Square	450x450	610x610	80	30	40	500x500	40
	KKC MHCF - 09	Light Duty- 2.5	Rectangular	600x450	780x630	80	30	40	670x520	40
	KKC MHCF - 10	Gully Trap	Square	260x260	390x390	75	20	30	300x300	40
	KKC MHCF - 01	Gully Grating	Rectangular	500x450	680x630	120	30	50	570x520	70
	KKC MHCF - 02	Gully Grating	Rectangular	600x300	770x470	120	30	50	670x370	70

Konkrete Concepts Precast Concrete Products are manufactured by using color concrete, fibre concrete and polymer concrete grade of M-30 and above. We use latest vibro-compaction techniques to manufacture our products. In our constant endeavour to improve the products, the specifications may change without notice.

(All Dimension are in mm.)

e-mail : [konkretkoncepts@gmail.com](mailto:konkretkoncepts@gmail.com)



Bottom View of Drain Cover

**DRAIN COVER**

Drain Cover, Indrapuram, Ghaziabad

<p>Drain Cover and Lid</p>	<p>Saucer Drain Gratings</p>	<p>Drain Cover</p>
<p>Drain Cover</p>	<p>Trench Cover</p>	<p>Saucer Drain</p>



Product Picture



Product Code	W	D	T	L
KKC DR- 01	200	250	50	500
KKC DR- 02	300	300	50	500
KKC DR- 03	300	375	50	500
KKC DR- 04	300	450	50	500
KKC DR- 05	350	500	60	400
KKC DR- 06	340	315	70	610
KKC DR- 07	585	310	70	610
KKC DR- 08	685	355	80	475

Product Description

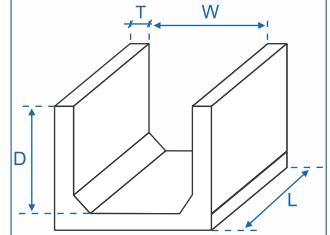

Product Picture



**SIZES OF DRAIN COVER**

Product Code	Width	Length	Thickness
KKC LID- 01	600	450	60
KKC LID- 02	750	600	70
KKC LID- 03	900	450	90
KKC LID- 04	1150	400	100
KKC LID- 05	400	500	50
KKC LID- 06	400	500	70
KKC LID- 07	300	600	70
KKC LID- 08	400	600	70
KKC LID- 09	450	600	60
KKC LID- 10	450	600	75
KKC LID- 11	400	800	90
KKC LID- 12	400	800	70
KKC LID- 13	750	1600	150

Product Description

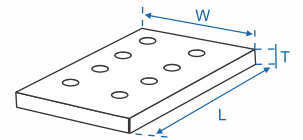

Product Picture



**SIZES OF SAUCER DRAIN**

Product Code	Width	Length	Thikness Centre	Thikness End
SD 01	450	300	75	100
SD 02	600	450	75	100
SD 03	300	900	75	100
SD 04	450	600	75	100

Product Description

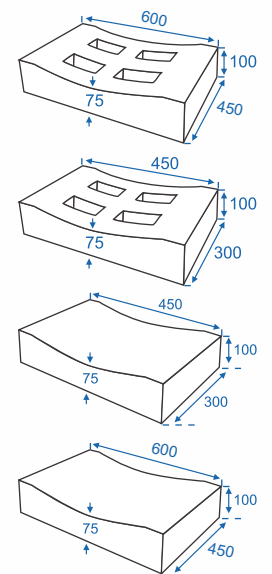



## FENCE, BOLLARD & TREE GUARDS





## SOCCER BOLLARD



### Picture Specification Dimension

Total Height = 880mm

Dia = 450mm

Base Dia = 200mm

Manufacture using the Vibrio Compaction Techniques M 30 Grade of Concrete and Suitable Reinforcement

### Merits

- (1) Soccer Bollard Can Enhance any Stadium Entrance
- (2) Security Option
- (3) To show The way to your Stadium
- (4) Fun way to make Each Fairway on your Course



**KKC**

**FENCE, BOLLARD  
& TREE GUARDS**

**CYLINDRICAL BOLLARD**

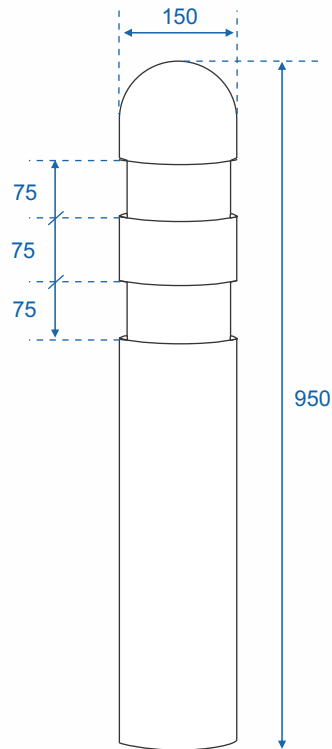

Konkrete Koncepts Precast Concrete Products are manufactured by using color concrete, fibre concrete and polymer concrete grade of M-30 and above. We use latest vibro-compaction techniques to manufacture our products. In our constant endeavour to improve the products, the specifications may change without notice.

(All Dimension are in mm.)

e-mail : [konkretkoncepts@gmail.com](mailto:konkretkoncepts@gmail.com)



# FENCE, BOLLARD & TREE GUARDS



FENCES DIAMOND

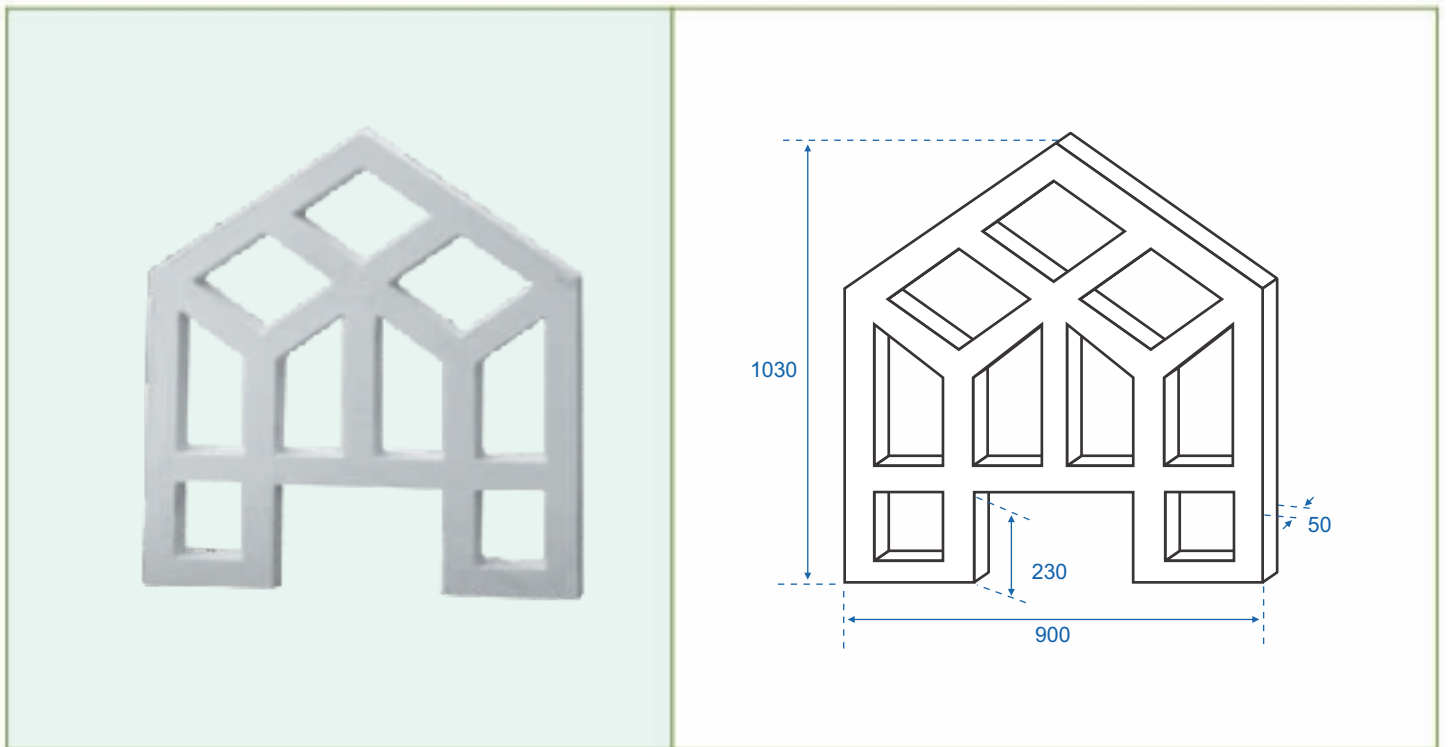

Konkrete Concepts Precast Concrete Products are manufactured by using color concrete, fibre concrete and polymer concrete grade of M-30 and above. We use latest vibro-compaction techniques to manufacture our products. In our constant endeavour to improve the products, the specifications may change without notice.

(All Dimension are in mm.)

e-mail : [konkretkoncepts@gmail.com](mailto:konkretkoncepts@gmail.com)



# FENCE, BOLLARD & TREE GUARDS

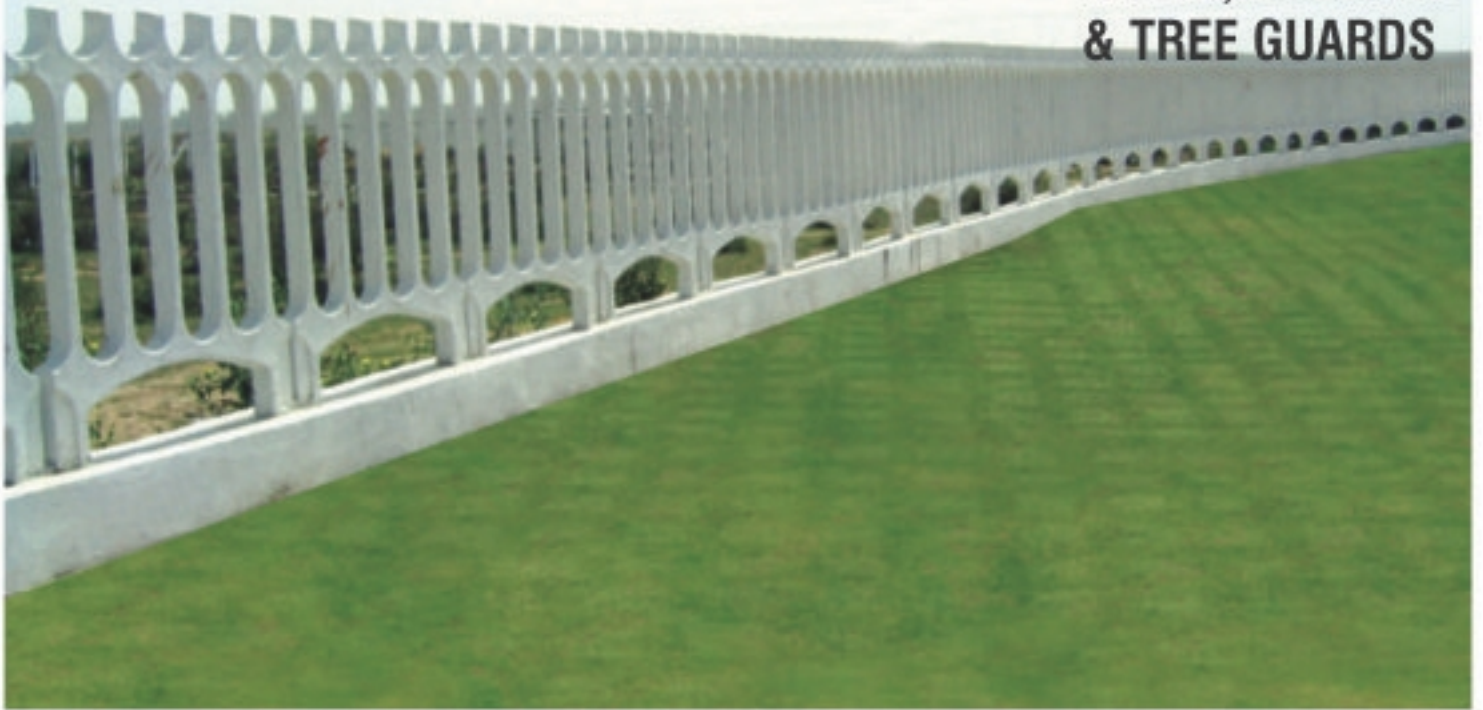

**FENCE MAJESTIC**

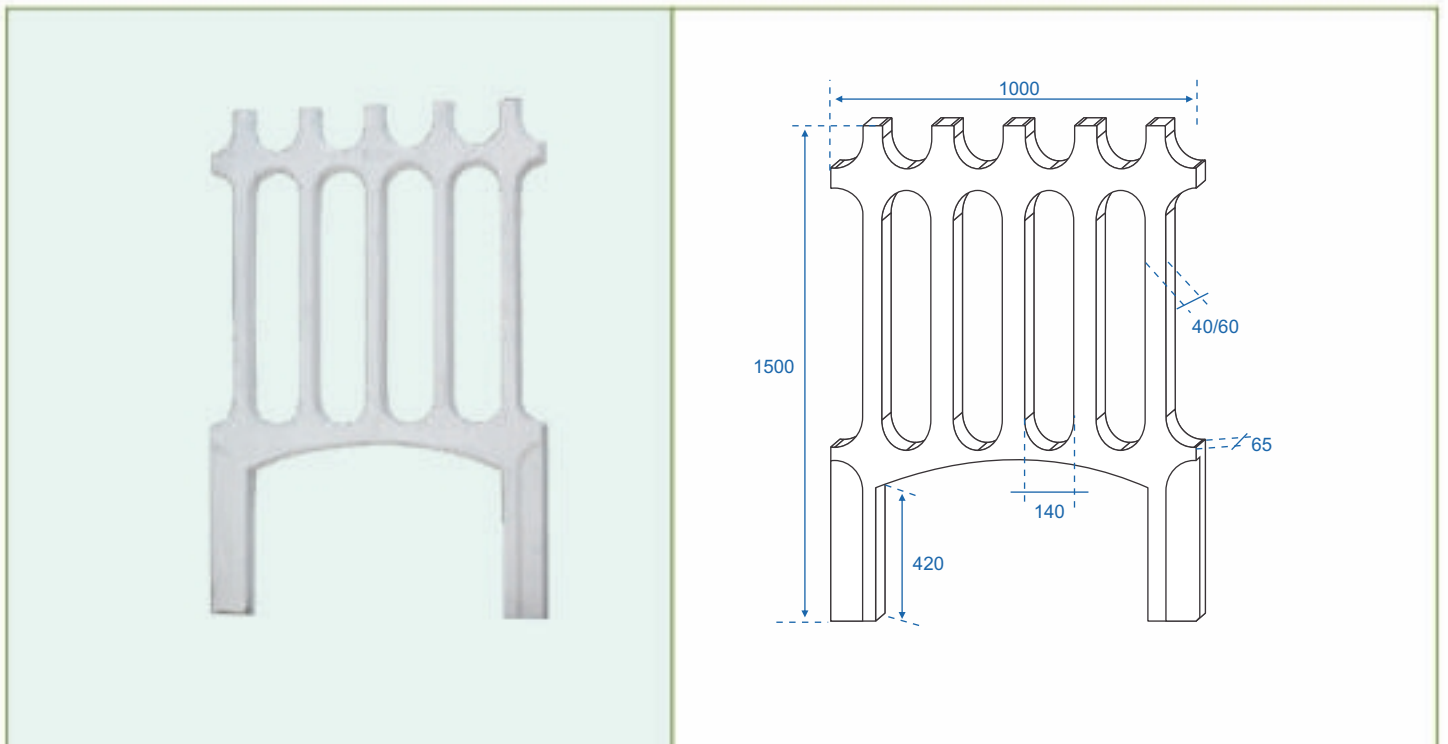

Konkrete Koncepts Precast Concrete Products are manufactured by using color concrete, fibre concrete and polymer concrete grade of M-30 and above. We use latest vibro-compaction techniques to manufacture our products. In our constant endeavour to improve the products, the specifications may change without notice.

(All Dimension are in mm.)

e-mail : [konkretkoncepts@gmail.com](mailto:konkretkoncepts@gmail.com)



# FENCE, BOLLARD & TREE GUARDS



FENCES “V” SHAPE

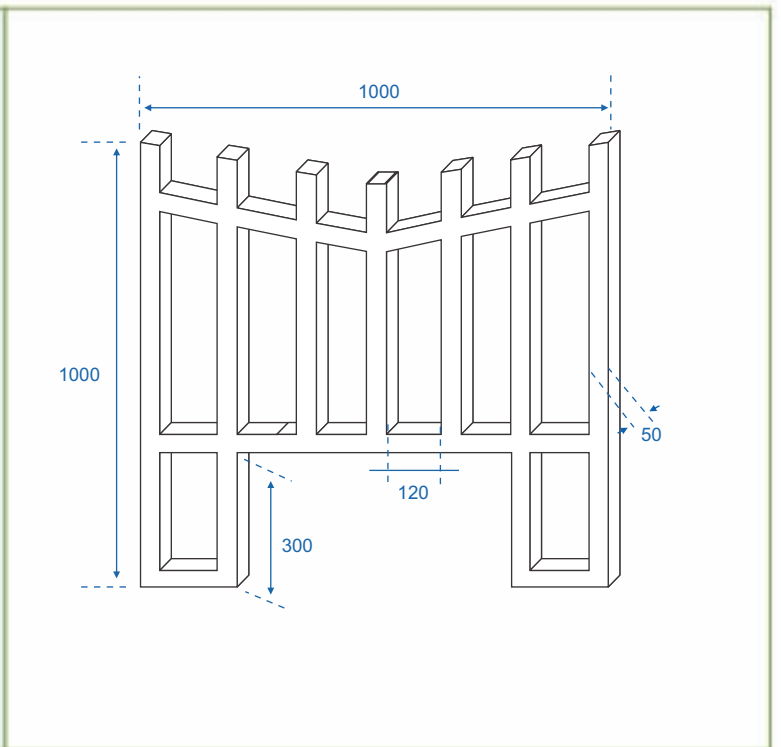

Konkrete Concepts Precast Concrete Products are manufactured by using color concrete, fibre concrete and polymer concrete grade of M-30 and above. We use latest vibro-compaction techniques to manufacture our products. In our constant endeavour to improve the products, the specifications may change without notice.

(All Dimension are in mm.)

e-mail : [konkretkoncepts@gmail.com](mailto:konkretkoncepts@gmail.com)



**TREE GUARD**

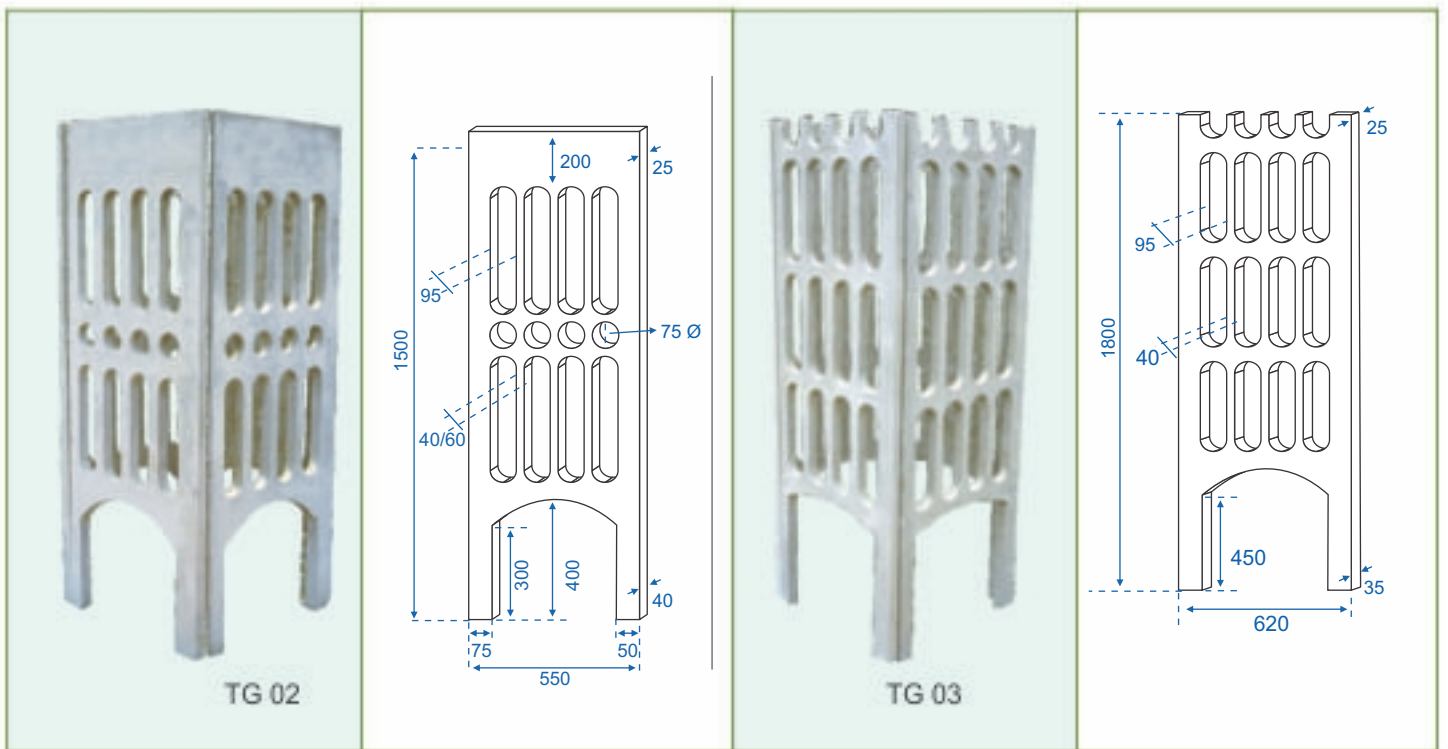

Konkrete Concepts Precast Concrete Products are manufactured by using color concrete, fibre concrete and polymer concrete grade of M-30 and above. We use latest vibro-compaction techniques to manufacture our products. In our constant endeavour to improve the products, the specifications may change without notice.

(All Dimension are in mm.)

e-mail : [konkretekoncepts@gmail.com](mailto:konkretekoncepts@gmail.com)





FENCE, BOLLARDS  
& TREE GUARDS



TREE GUARD

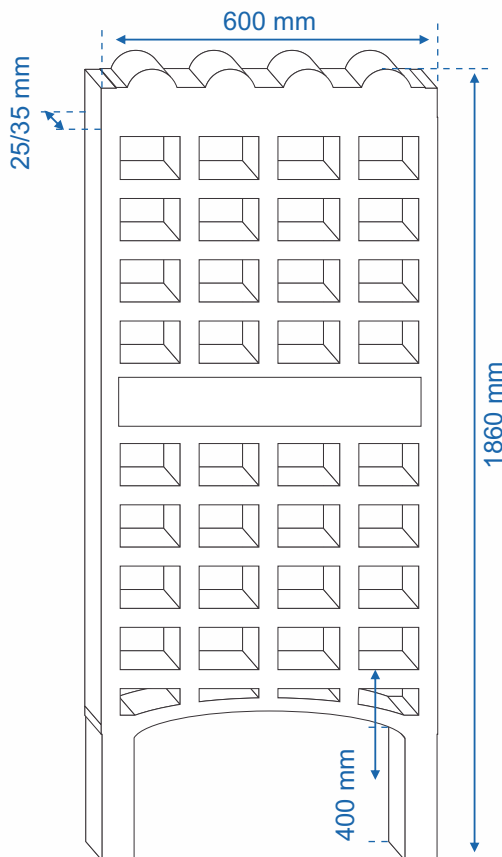

Hight : 1860 mm  
Width : 600 mm  
Thickness : 25/35 mm  
Size of opening : 100x100  
Color : Natural (Grey)  
Grade of concrete :M-30

Konkrete Concepts Precast Concrete Products are manufactured by using color concrete, fibre concrete and polymer concrete grade of M-30 and above. We use latest vibro-compaction techniques to manufacture our products. In our constant endeavour to improve the products, the specifications may change without notice.

(All Dimension are in mm.)

e-mail : [konkretkoncepts@gmail.com](mailto:konkretkoncepts@gmail.com)



**KKC**

**FENCE, BOLLARD  
& TREE GUARDS**

**TREE SURROUND**

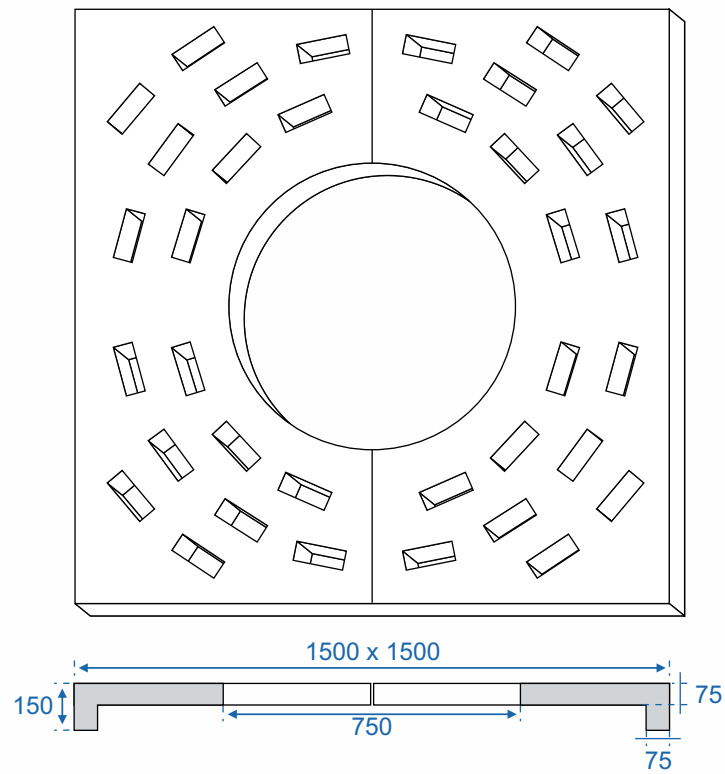

Konkrete Concepts Precast Concrete Products are manufactured by using color concrete, fibre concrete and polymer concrete grade of M-30 and above. We use latest vibro-compaction techniques to manufacture our products. In our constant endeavour to improve the products, the specifications may change without notice.

(All Dimension are in mm.)

e-mail : [konkretkoncepts@gmail.com](mailto:konkretkoncepts@gmail.com)

INTRODUCING

KKC PRECAST POLYMER CONCRETE PRODUCTS

KKC PRECAST VIBRO COMPACTED CONCRETE PRODUCTS

KKC PRECAST COLOURED CONCRETE PRODUCTS

KKC PRECAST FIBRE REINFORCED CONCRETE PRODUCTS



**KKC**

**KONKRETE KONCEPTS COMPANY**

ENGINEERS / DESIGNERS / CONTRACTOR

171/2, Village Bhakri, Faridabad (Haryana)

Tel. : +91 129 2480064 Mobile : +91 9999181563, 9999371980, 9811437574

e-mail : [konkrekoncepts@gmail.com](mailto:konkrekoncepts@gmail.com)